



SITESCAPES

P.O. Box 22326
Lincoln, NE 68542

PF: 402/421-9464
FX: 402/421-9479

WEBSITE: www.sitescapesonline.com
E-MAIL: info@sitescapesonline.com

TITLE *TALLGRASS
TRASH RECEPTACLE*

PRODUCT NO.
TG2-3007

INCH TOLERANCES U.O.S.
FRACTION-- $\pm 1/16"$
ANG----- $\pm 1^\circ$

THE INFORMATION CONTAINED IN THIS DRAWING IS THE SOLE PROPERTY OF SITESCAPES, INC. ANY REPRODUCTION IN PART OR AS A WHOLE WITHOUT THE WRITTEN PERMISSION OF SITESCAPES, INC. IS PROHIBITED.

*Available in powder coat and DuraCoat finishes

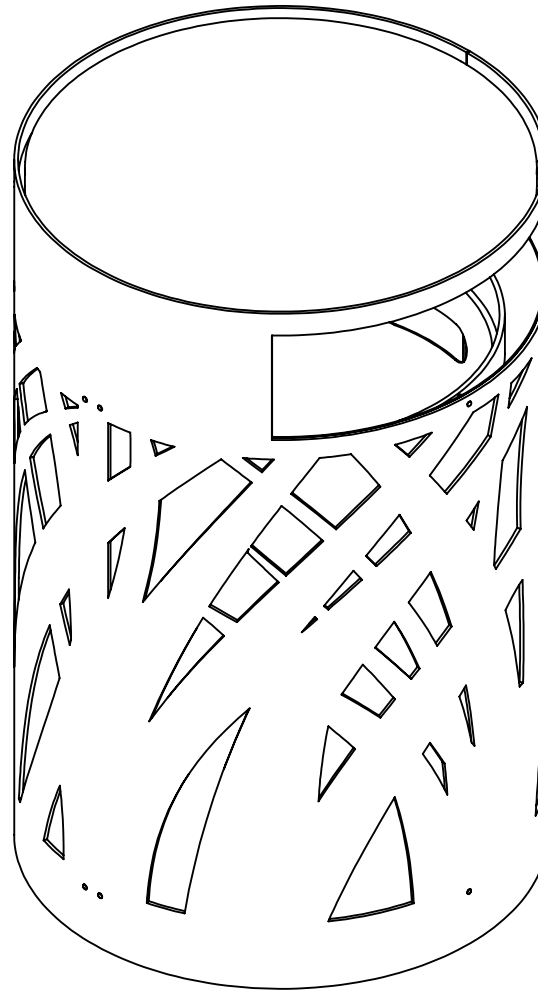



SITESCAPES

P.O. Box 22326
Lincoln, NE 68542

PF: 402/421-9464
FX: 402/421-9479

WEBSITE: www.sitescapesonline.com
E-MAIL: info@sitescapesonline.com

TITLE *TALLGRASS
TRASH RECEPTACLE*

PRODUCT NO. *TG2-3007*

INCH TOLERANCES U.O.S.
FRACTION-- $\pm 1/16"$
ANG----- $\pm 1^\circ$

THE INFORMATION CONTAINED IN THIS DRAWING IS THE SOLE PROPERTY OF SITESCAPES, INC. ANY REPRODUCTION IN PART OR AS A WHOLE WITHOUT THE WRITTEN PERMISSION OF SITESCAPES, INC. IS PROHIBITED.

*Available in powder coat and DuraCoat finishes

MATERIALS LIST:

- (1) Container - 7 Gauge Laser Cut Steel
- (2) Backing Plate- 1/16" Aluminum Sheet
- (3) Support Bars - 1" x 3/4" Steel Flat Bar
- (4) Lid - $\phi 24"$ x .075" Wall Steel Lid
Attached to Basket with Stainless Steel Aircraft Cable
- (5) Surface Mount Plates - 1/4" x 1 1/2" Stainless Steel Plate with 9/16" Mounting Hole
- (6) Mounted with Three $\phi 1/2"$ x 4-5" Stainless Steel Anchor Bolts (Customer Supplied)
- (7) 36 Gallon Rigid Plastic Liner with Handles Included

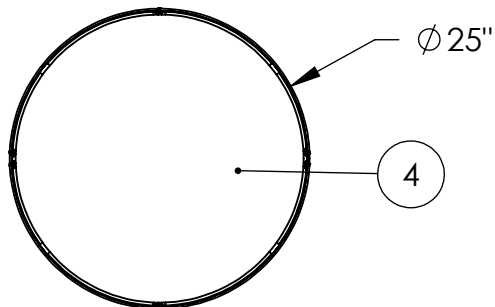

TOP VIEW

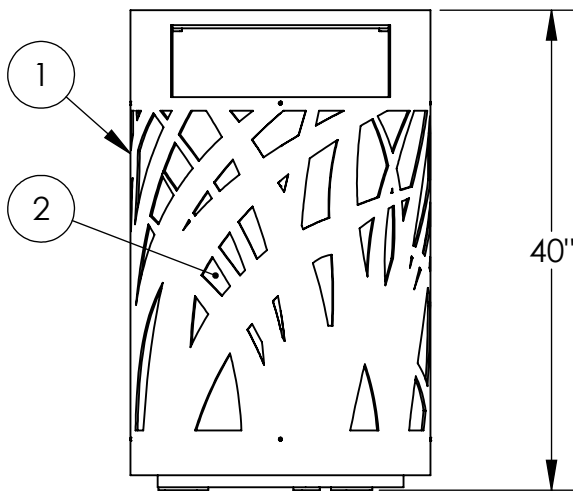

FRONT VIEW

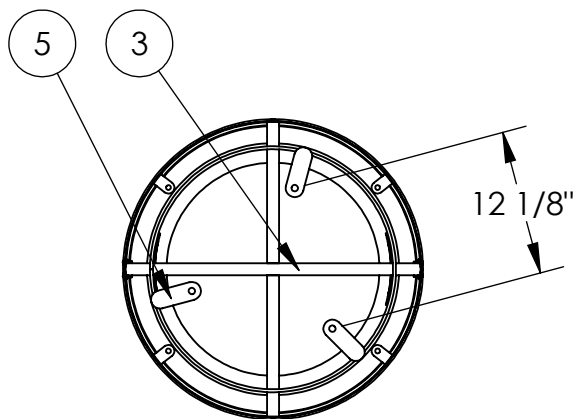

BOTTOM VIEW

